

## Delta 14 AHU Technical Information

Specialist Design, Support and H & V  
solutions for all wet leisure projects



### Solutions for:

- Humidity control
- Pool water heating
- Ventilation
- Air cooling
- Recovering energy
- Air heating

## **Specification - Model Delta 14 - General**

Supply one specifically designed swimming pool heat recovery and dehumidification unit as follows: -

### **Unit comprising: -**

- Galvanised and plastisol coated insulated steel cabinet, panels with quick release fasteners, mounted on a hot dip galvanized chassis.
- Variable speed EC main recirculation fan.
- Variable speed EC exhaust fan.
- Filters for recirculation and fresh air inlets.
- Fresh air louvre dampers driven by a controlled positioning motor, for automatically regulated introduction of fresh air, set to provide pool hall negative pressure.
- Heat pump dehumidifier for the recirculation and exhaust airflows incorporating heat recovery to pool water and pool hall air.
- Fully controlled LPHW air heater battery.
- Fully controlled LPHW pool water calorifier.
- Integral control panel complete with sensors and controllers for:
  - Humidity
  - Air temperature
  - Pool water temperature
  - Comprehensive running and fault indicators
- Optional features

## **Specification - Model Delta 14 - Detail**

### **Chassis and Cabinet**

The chassis shall be fabricated from cold rolled mild steel section hot dip galvanized. The cabinet shall be formed from galvanised and plastisol coated steel sheet and insulated internally with expanded P.V.C. foam sheet, type 3509, having density of 260 kg/m<sup>3</sup> and thermal conductivity  $K = 0.043 \text{ W/mK}$ .

The unit shall be totally insulated and panels shall be removable for service and for access to fresh air and recirculation filters. Panels shall be manufactured from galvanised steel sheet with outer sides having plastisol coating leathergrain. The inside shall be insulated as previously described. Service panels shall have quick release fasteners.

The whole construction of the unit shall be designed to withstand the corrosive atmosphere normally experienced in a swimming pool building. A compact solution, the unit shall come as one piece, overall size 2798mm long x 1126mm wide x 2120mm high

### **Main Recirculation Fan**

The main recirculation fan shall be capable of circulating 10,000 m<sup>3</sup>/h (2.77 m<sup>3</sup>/s) pool hall air against an external total pressure loss of 80mm wg. It shall be driven by an electrically commutated direct drive motor. The motor shall be protected by a 3 phase motor start circuit breaker. The main fan shall run continuously with speed determined by the control system.

### **Exhaust Air Fan**

The exhaust air fan shall be capable of exhausting up to 6,700 m<sup>3</sup>/h (1.86m<sup>3</sup>/s) used air against an external total pressure loss of 50mm wg. It shall be driven by an electrically commutated direct drive motor. The motor shall be protected by a 3 phase motor start circuit breaker. The exhaust fan shall run continuously with speed determined by the control system.

### **Air Filters**

The unit shall be complete with recirculation and fresh air filters which shall be easily changed. The filters shall be 50mm deep disposable panel filters, bonded glass fibre type with an EN 779 classification of G2.

### **Exhaust/Fresh Air Dampers**

Exhaust air delivered by the exhaust fan to atmosphere shall be quantitatively varied by the exhaust fan speed controller. Fresh air shall be varied by an inlet damper, driven by a dedicated multi-position control motor. The dampers shall be galvanised geared units of high quality construction and shall be set such that the pool hall is maintained under negative pressure.

Signal for the control motor shall be provided from the integral control panel. The exhaust air volume shall be automatically modulated by the control system from a minimum flow of 670m<sup>3</sup>/h up to a maximum of 6,700m<sup>3</sup>/h, which shall be influenced by the following parameters:-

- The pool hall humidity
- The pool hall temperature
- The external ambient temperature
- The air quality sensor (if fitted) detecting deterioration of the pool hall air condition

### **Heat Recovery Heat Pump Dehumidifier**

The heat pump shall be capable of acting as a heat recovery dehumidifier from the recirculating and exhaust air when required, and as a refrigerated air conditioning unit when the pool air conditions rise above the pool hall temperature set point. It shall be automatically controlled from the integral control panel.

It shall have a net heat recovery capacity of 42kW at pool conditions of 28°C and 60%RH. During heat recovery the energy shall be capable of being fed into the pool water and/or air. During air conditioning, the recovery energy shall be automatically directed to the pool water and/or rejected at the exhaust air condenser whichever is appropriate.

Evaporators and air condensers shall be of copper tube with aluminium fins protected by high integrity polyester coating. Pool water condenser shall be a shell and tube type constructed from steel (shell) and extended surface 90/10 seamless marine grade cupro-nickel where in contact with the pool water (tube).

### **Auxiliary air heating**

An LPHW air heater battery with fully controlled valve shall be provided, rated at 85kW, to provide heat to the air stream, with 78kW available for building fabric losses with fresh air at -5°C. The heat output shall be rated with LPHW supplied from an external source at a flow temperature of 80°C. The heater battery shall be of copper tube with aluminium fins protected by high integrity polyester coating.

### **Auxiliary pool water heating**

An LPHW pool water calorifier with fully controlled valve shall be provided, rated at 65kW, to provide top up heat to the pool water to make up unrecoverable losses. The heat output shall be rated with LPHW supplied from an external source at a flow temperature of 80°C. The heat exchanger shall be manufactured from extended surface 90/10 cupro-nickel where in contact with the pool water.

## Specification - Model Delta 14 - Controls

The control panel shall be integral with the unit and all necessary sensors, controllers, motor starters, overloads and circuit breakers shall be integrated within the cabinet. The unit shall control the following parameters:-

- Humidity 2 stages
- Air temperature 3 stages (including unoccupied set-back)
- Pool water temperature 2 stages

Control of humidity, air temperature and water temperature shall be by PLC digital controllers which shall provide displays of actual and set point readings.

The main and exhaust fan motors shall be run at high speed when either dehumidification or air heating via LPHW is required. The fan motors shall be run at low speed at all other times.

An integral time clock shall be provided to work in conjunction with the third air temperature stage to cater for unoccupied air temperature set back for energy economy, if a pool cover is used.

A 2-position ON-OFF function shall be provided on the control panel.

A 2-position WATER-AIR function shall be provided on the control panel to override heat recovery priority.

A 2-position ENABLE-DISABLE function shall be provided on the control panel to allow manual override of air conditioning operation.

A 3-position MAX-AUTO-MIN function shall be provided on the control panel to allow manual override of fresh air operation.

A 2-position FULL OPERATION WATER ONLY function shall be provided to choose between all functions operation and water heating only operation.

Warning indicator lights shall be provided on the control panel to indicate the following conditions:-

- Mains ON
- Compressor Fault
- Compressor Defrost
- Fresh air operation Auto

Indicator lights shall be provided on the control panel to indicate when the machine is providing:-

- Dehumidification by heat pump
- Air heating via LPHW
- Air cooling by heat pump
- Water heating via LPHW

The following remote contacts shall be available at the main terminal block to provide the following control interfaces: -

- Remote on/off (230V supplied from machine) - duplicates function of 2-position ON-OFF switch on control panel.
- Indication of auxiliary water heater or air heater in operation, requiring LPHW to be supplied (volt-free contacts) - can control a dedicated boiler to switch ON or OFF as determined by machine or to control a 3 port bypass valve if required.
- Indication that pool pump is required to run (12V supplied from machine) - can control a dedicated pool water pump to come on only when required for heat recovery to pool water or auxiliary water heating.
- Remote override of occupied/unoccupied mode (12V supplied from machine) - can override the integral time clock to put the control system into occupied mode when pool is uncovered.

The following volt-free pairs shall be available to provide remote indication of:-

- Machine on
- Main fan running
- Exhaust fan running
- Compressor running
- Compressor fault

An ambient air temperature control shall be provided in the fresh air inlet to control reduction of fresh air quantity in cold weather at an adjustable threshold.

An air temperature control shall be provided to control the unoccupied air temperature.

A flow meter shall be provided to indicate the pool water flow through the heat recovery condenser.

A phase rotation protection relay shall be provided on three phase machines to prevent operation in the event of incorrect phase rotation.

## **Optional features**

The following optional features shall be available on request: -

- The main and/or exhaust fan speeds can be varied to provide increased external static pressure.
- Air differential pressure switches can be fitted across main and/or exhaust fans to detect fan pressure and provide a fan failure signal.
- Air differential pressure switches can be fitted across recirculation filters to detect the filter pressure drop and provide a filter dirty signal.
- An air quality monitor can be provided to detect deterioration in pool hall air condition and force the maximum quantity of fresh air to be introduced.
- The LPHW air heater battery can be upgraded to compensate for lower LPHW flow temperatures.
- The LPHW air heater battery can be provided with frost protection to force the minimum quantity of fresh air to be introduced.
- The digital controllers can be provided with an optional RS485 interface using a MODBUS protocol, thus allowing interface with a BMS to monitor and alter set point values remotely.
- The air temperature and humidity sensors can be fitted in a remote sensor enclosure to provide remote measuring of pool hall relative humidity and air temperature.
- The compressor can be fitted with a soft-start.

# DELTA MODEL 14 & 16

POOL WATER IN/OUT = 1 1/2 BSPM  
 BOILER WATER IN/OUT = 1 1/2 BSPM  
 DRAIN = 3/4 BSPM  
 \* SEE DUCT DIMENSION DATA

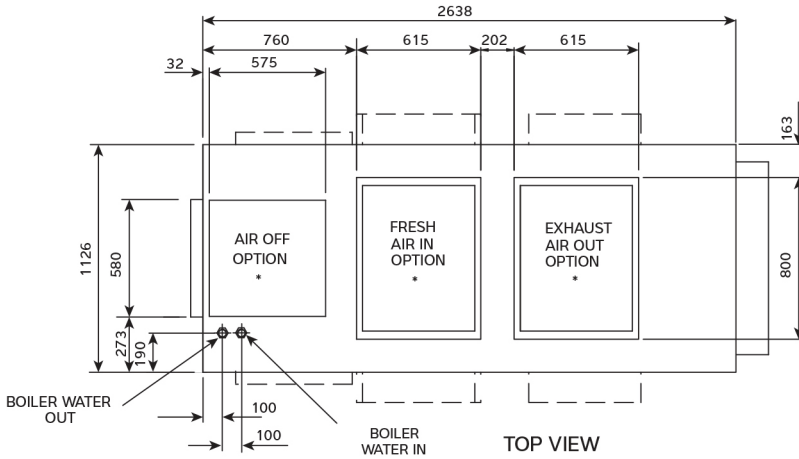

TOP VIEW

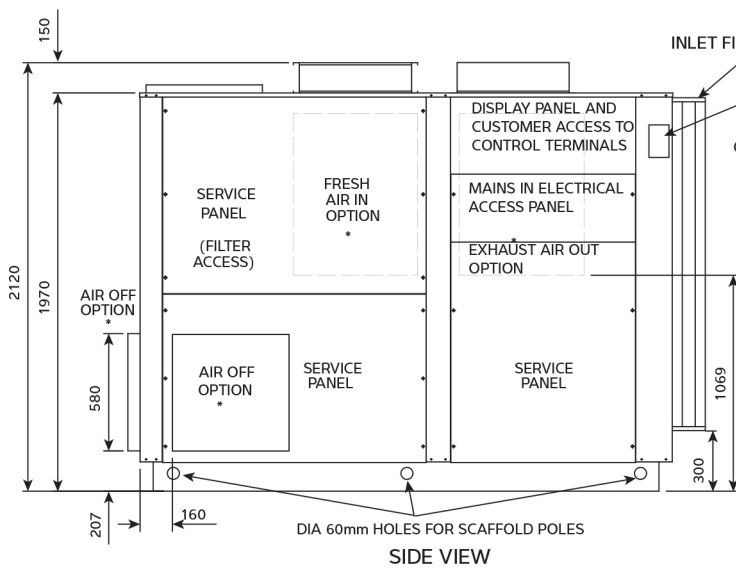

SIDE VIEW

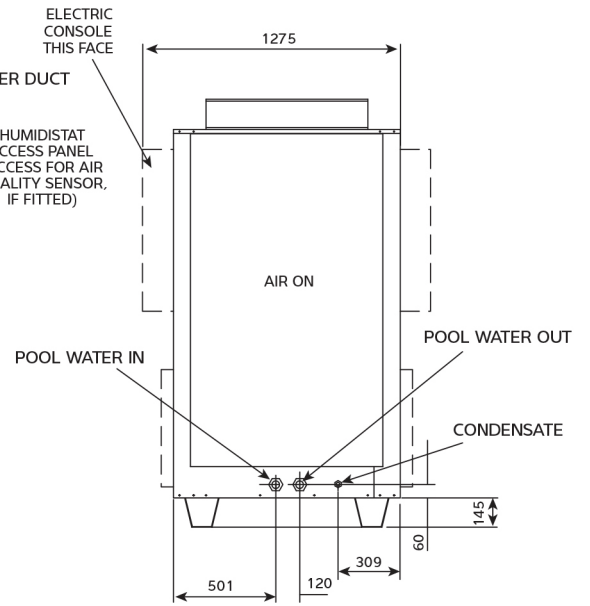

SIDE VIEW

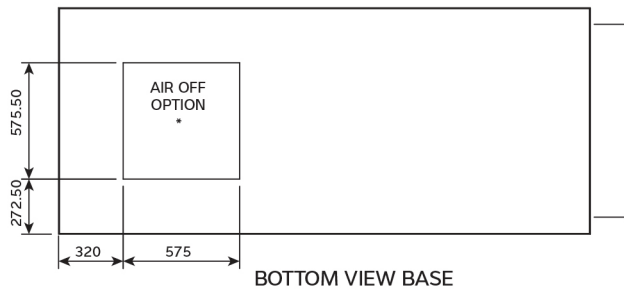

BOTTOM VIEW BASE

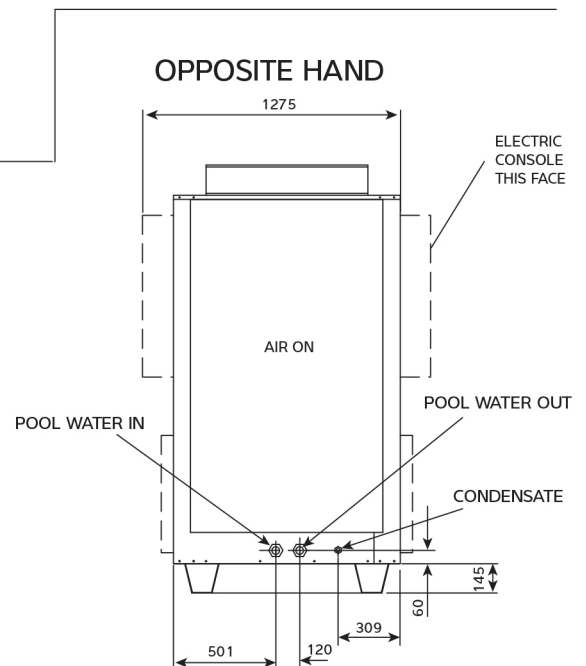
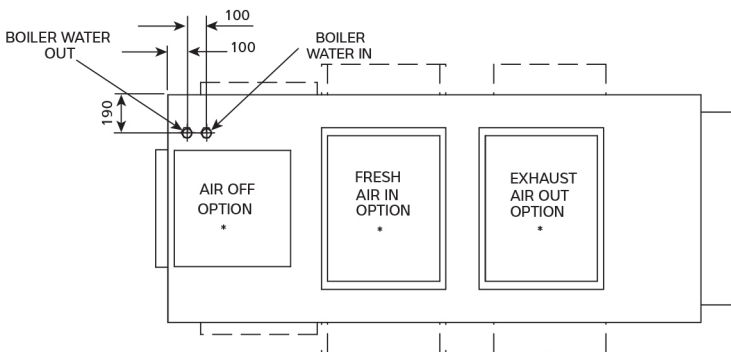

OPPOSITE HAND



**DELTA 14 & DELTA 16  
DUCT DIMENSION DATA**

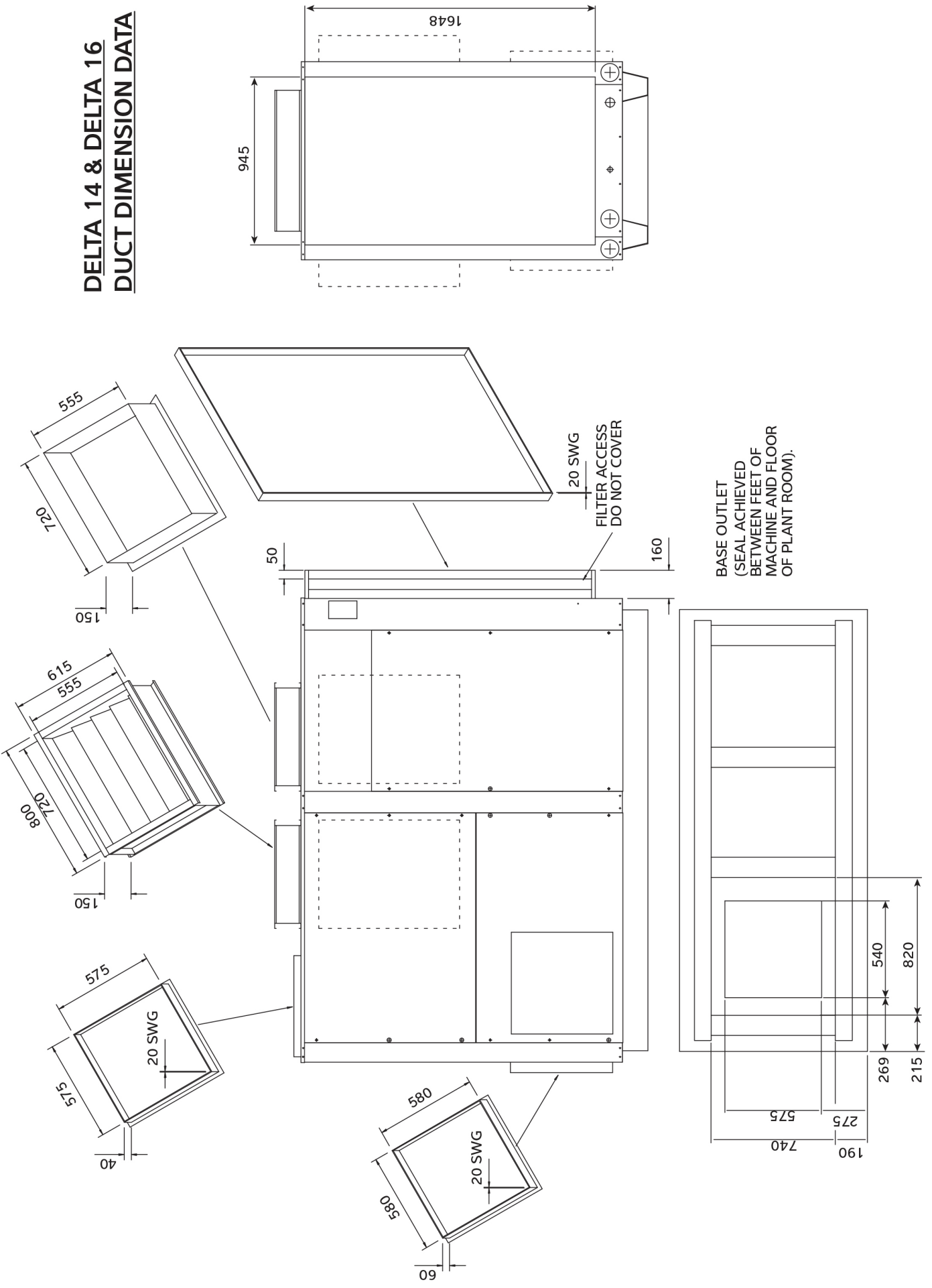

## Data Sheet - Delta 14

<b>Dehumidification Duty</b> Via Heat Pump (28°C / 60%/rh) (Dampers Min) l/hr 28 Total @ 18°C Dewpoint (Summer) (Damper Max) l/hr 41 Total @ 7°C Dewpoint (Winter) (Damper Mid) l/hr 55 VDI 2089 l/hr 42.5 Total DH + VDI 2089 @ 12.5°C Dewpoint (Summer) l/hr 56.5	<b>Recommended Boiler Capacity</b> Flowrate l/min 115 Pressure Drop @ Rated Flow m/hd 4.0 Max Delta System Working Pressure bar 6
<b>Heat To Air</b> Via Heat Pump (Mode A) kW 6 Via Heat Pump (Mode B) kW 30 Via LPHW @ 80°C kW 85 Total kW 91/115	<b>Electrical</b> Total Power Consumed (Nominal) kW 12.3 Min Supply Capacity (Max FLA) 3ph N amps 38 Max Supply Fuse 3ph N amps 50
<b>Building Heat Loss</b> Heat Required For Fresh Air @ -5°C kW 37 Available For Fabric Losses @ -5°C kW 78	<b>Main Fan</b> Air Flow m³/hr 10000 Max Static Pressure mmWg 80 FLA 3ph N amps 8
<b>Heat To Pool Water</b> Via Heat Pump (Mode A) kW 35 Via Heat Pump (Mode B) kW 12 Via LPHW @ 80°C kW 65 Total kW 100/77 Flow Rate Pool Water ± 10% l/min 100 Pressure Drop @ Rated Flow m/hd 3.5 Max Working Pressure bar 3.5 Internal Condenser Taco Pool Water Setting l/min N/A	<b>Exhaust Fan</b> Air Flow (Summer) m³/hr 6700 Air Flow (Winter) m³/hr 3350 Air Flow (Unoccupied) m³/hr 670 Max External Static Pressure mmWg 50 FLA 3ph N amps 6.2
<b>Cooling Duty</b> Cooling Duty (Sensitive) mode A/B Cooling Duty (Total) kW - 13 kW - 23	<b>Compressor</b> Nominal Power Consumed kW/hr 8.2 LRA 3ph N amps 102 RLA 3ph N amps 14.1 Soft Start Amps 3ph N amps 34
	<b>General Data - Hermetic System</b> Gas Charge (R407c) kg 21.5 Weight Approximately kg 954

For accurate application sizing please consult Calorex Heat Pumps Ltd

Mode A = recovered heat biased to pool water (Pool water temp not satisfied)  
 Mode B = recovered heat biased to pool hall air (pool water temp satisfied)  
 R407c Global Warming Potential (GWP) 1700

1mm WG = 9.8 Pa  
 1m hd = 1.4 psi  
 1l/min = 0.22 gal/min

## Warranty Conditions

The following exclusion apply to the Warranty given by Calorex Heat Pumps Ltd

No claims will be accepted if:

1. The Heat Pump is incorrectly sized for the application
2. The Heat Pump is installed in any way that is not in accordance with the current procedures as defined by Calorex Heat Pumps Ltd
3. The Heat Pump has been worked upon or is adjusted by anyone other than a person authorised to do so by Calorex Heat Pumps Ltd
4. The air flow to and from the machine is outside the specified limits
5. The water flow through the machine is outside the specified limits
6. The water pH level and / or chemical balance is outside the following limits

Acidity	pH	7.2-7.8
Total Alkalinity as CaCO <sub>3</sub>	ppm	80-120
Total Hardness as CaCO <sub>3</sub>	ppm	150-250
Total Dissolved Solids	ppm	1000
Maximum Salt Content	ppm	8000
Free Chlorine Range	ppm	1-2 Domestic
Free Chlorine Range	ppm	3-6 Commercial
Superchlorination	max	30ppm for 24 hours
Bromine	ppm	2-5
Baquacil	ppm	25-50
Ozone	ppm	0.9 Max
Max Copper Content	ppm	1
Aquamatic Ionic Purifier	ppm	2 Max
7. The Heat Pump has suffered frost damage
8. The electrical supply is insufficient or in any way incorrect
9. The fan amps and duct pressure are outside the specified limits
10. The Heat Pump must be maintained in accordance with service requirements in section 2.6.  
For details of the extended warranty and maintenance packages please call H & V Divison.



Office Use Only:	
Order No:	
Part No:	
Price	
Carriage	

### Order Confirmation Form For A Delta

Many thanks for your valued order for a Delta Swimming Pool Control Unit

Please specify configuration required below then confirm it is correct by signing and returning to us on

**Fax number 01993 778869**

To:	From:
Company:	Date:
Fax:	Ref:

Delta Model (* available in 3ph only)	Standard - Available in all models	Mirrored - Available in models 4-16
1		
2		
4		
6		
8 *		
10 *		
12 *		
14 *		
16 *		
Single Phase Y / N	Three Phase Y / N	Air Off: Top End Bottom

If the above does not correspond to your requirements please contact Certikin H & V Department to discuss options, alternatively, please liaise with your local distributor.

I confirm the above Delta configuration and specifications meet my requirements and that the unit is non-refundable for reasons of incorrect configuration / specification.

Sign: ..... Print Name: ..... Date: .....

I would like the Delta to be delivered to site Date: .....

Please Note: If the unit is in stock for more than 14 days after the above date, an invoice for 50% of the order total will be issued. The balance will be invoiced after a further 28 days. If no date is specified above, we will consider the site delivery date to be 6 weeks after the date of your purchase order.

Please note that your order will not be processed until we receive signed confirmation.

Standard lead time for a Delts 1-12 is approximately 4-5 weeks, the Delta 14-16 lead time is approximately 5-6 weeks, however this is dependant on seasonal demand.



**Certikin International Ltd,  
Witan Park, Avenue 2,  
Station Lane Industrial Estate, Witney,  
Oxfordshire, OX28 4FJ United Kingdom**

**Sales Tel: 01993 778855  
Admin Tel: 01993 777200  
Website: [www.certikin.co.uk](http://www.certikin.co.uk)  
Email: [info@certikin.co.uk](mailto:info@certikin.co.uk)**